

1 FLOOR PLAN
1/8" = 1'-0"

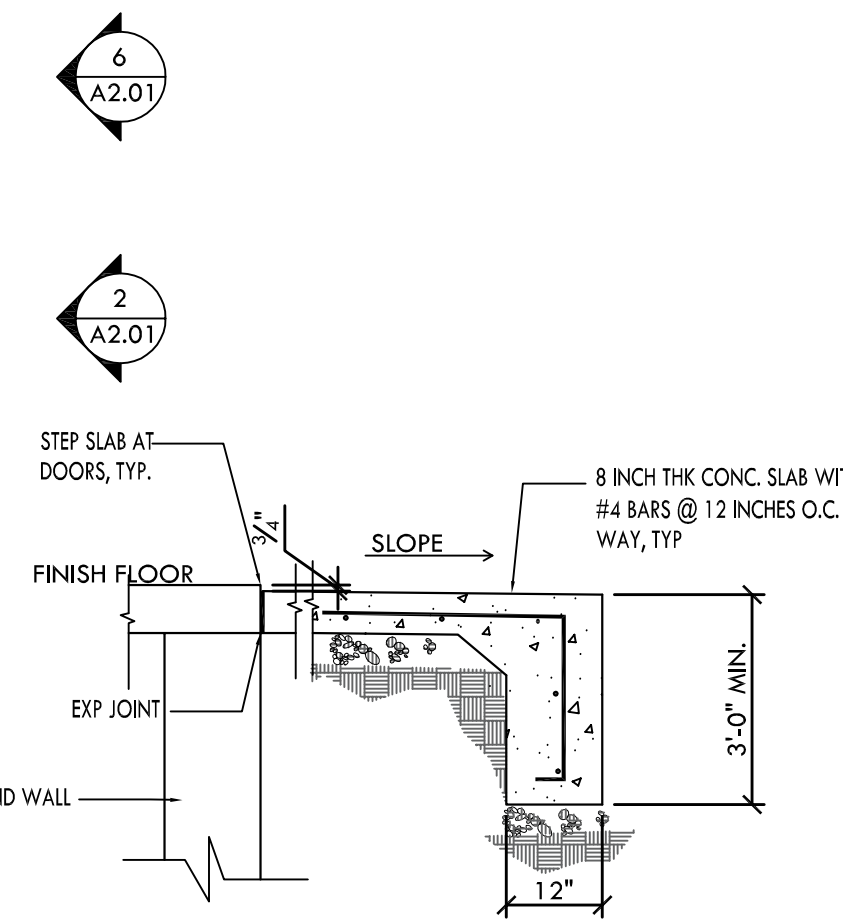

DOOR ELEVATION
1/4" = 1'-0"

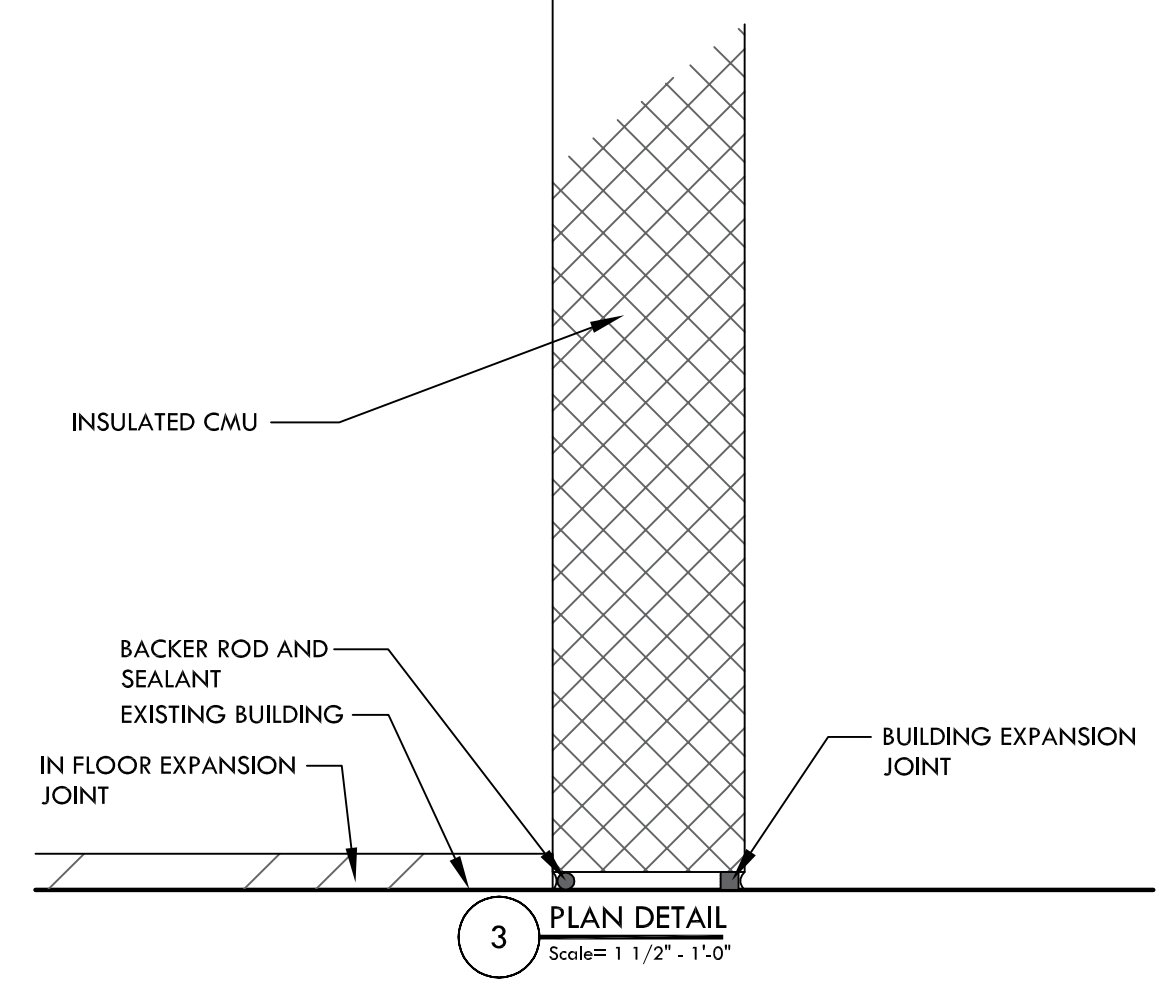
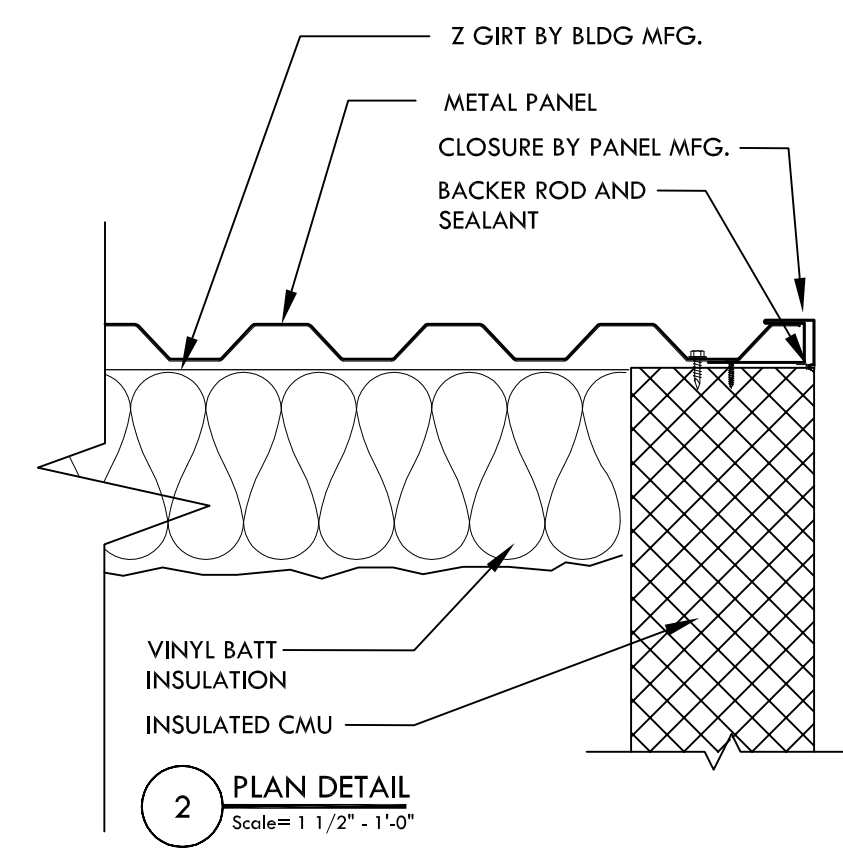
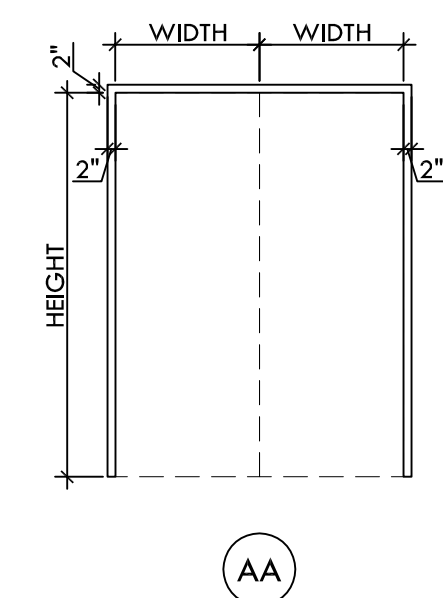
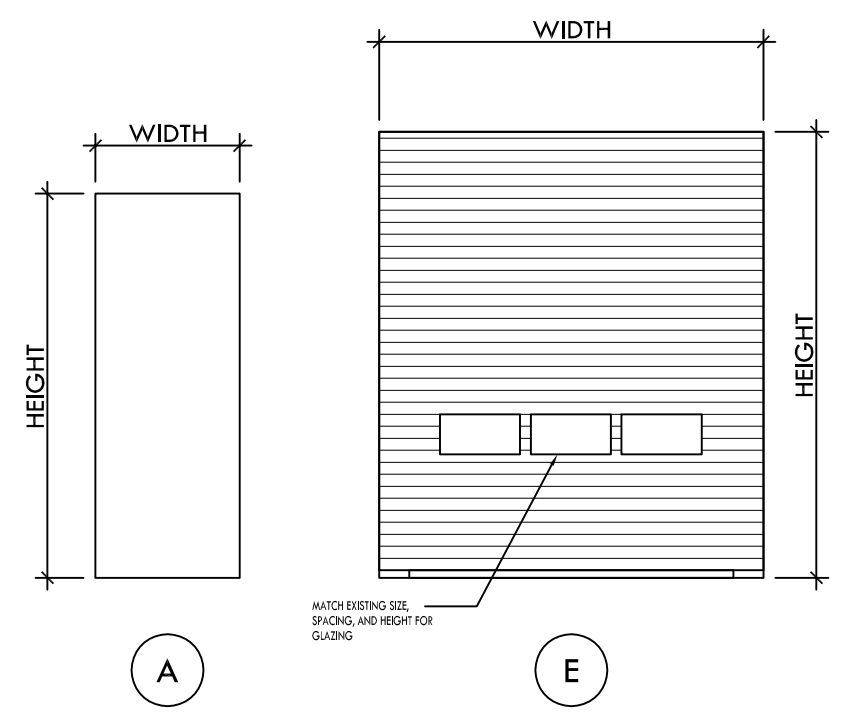

TYPICAL TURNDOWN SLAB/APRON
SCALE: 1/2" = 1'-0"

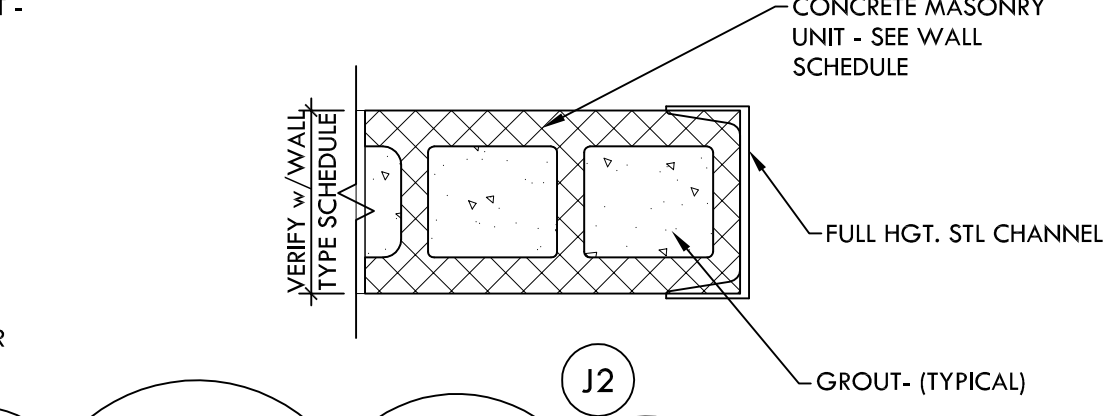
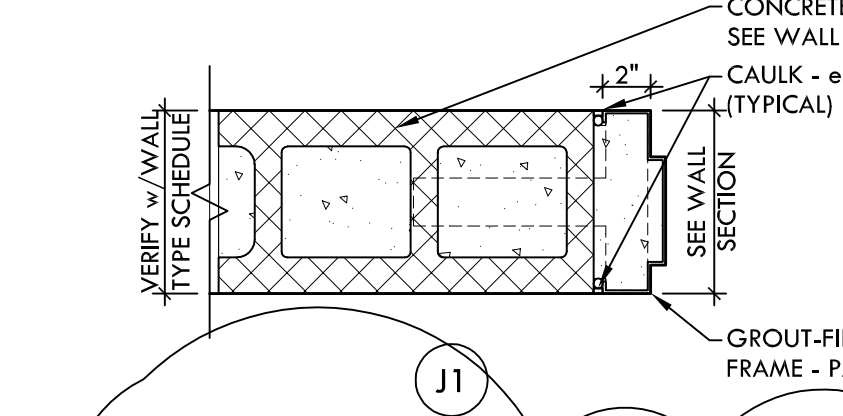
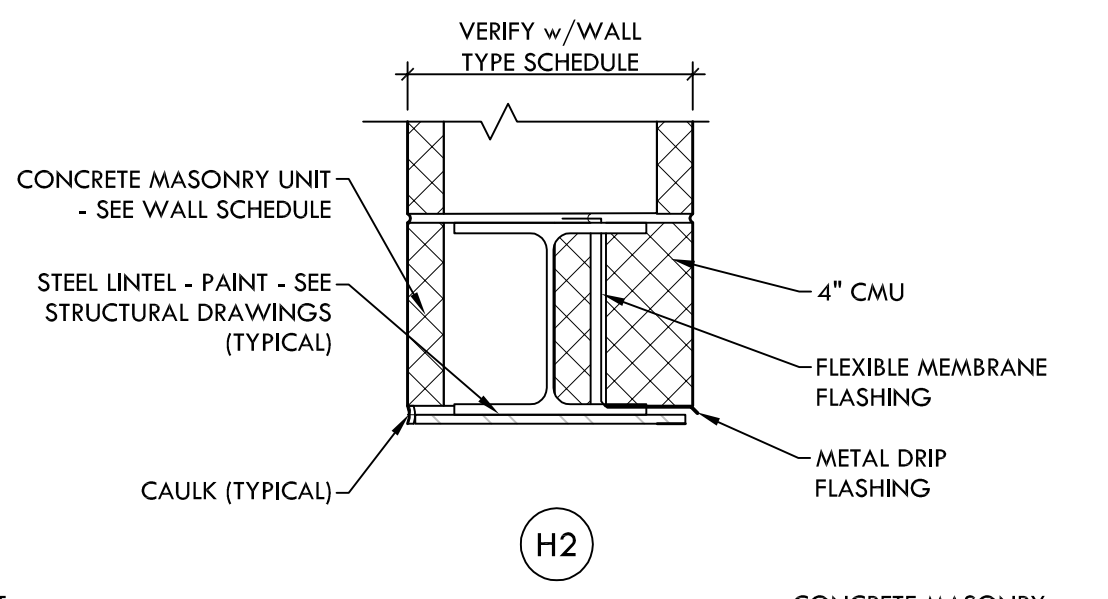
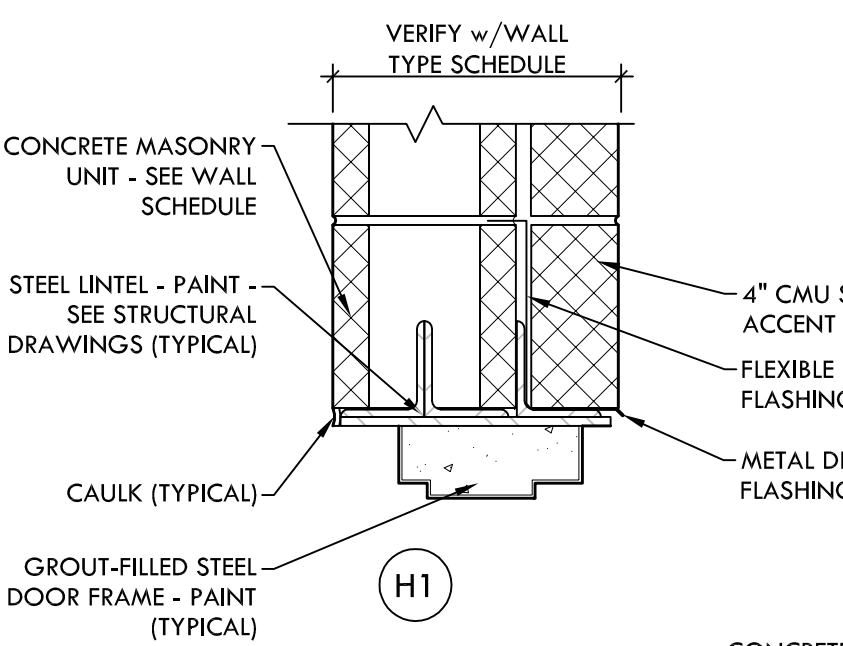

DOOR AND FRAME SCHEDULE

DOOR #	DOOR				FRAME				FIRE RATING LABEL	NOTES				
	WD	HGT	THK	MATL	FIN	GLAZING	ELEV	MATL			FIN	HEAD	JAMB	SILL
100	6'-0"	7'-2"	1 3/4"	HM	PAINT	-	A	HM	PAINT	H1	J1	-	AA	
101	12'-0"	14'-0"	1 3/8"	HM	MFG. CLR.; INSUL.	-	B	STEEL	PAINT	H2	J2	-	-	
102	14'-0"	12'-0"	1 3/8"	HM	MFG. CLR.; INSUL.	-	B	STEEL	PAINT	H2	J2	-	-	
103	14'-0"	10'-0"	1 3/8"	HM	MFG. CLR.; INSUL.	-	B	STEEL	PAINT	H2	J2	-	-	
104	3'-0"	7'-2"	1 3/4"	HM	PAINT	-	A	HM	PAINT	H1	J1	-	AA	
105	12'-0"	14'-0"	1 3/8"	HM	MFG. CLR.; INSUL.	-	B	STEEL	PAINT	-	-	-	-	
106	-	-	-	-	-	-	-	-	-	-	-	-	-	NEW CONTROLS ONLY

ALL DOOR HARDWARE IS TO BE COORDINATED WITH AND PROVIDED BY THE OWNERS VENDOR.

* CONFIRM OPENINGS WITH PRE-ENGINEERED LATERAL BRACING REQUIREMENTS